

25-01

トランスミッション ケース、カバー (ソノ 1)  
TRANSMISSION CASE & COVER  
(PART-1)

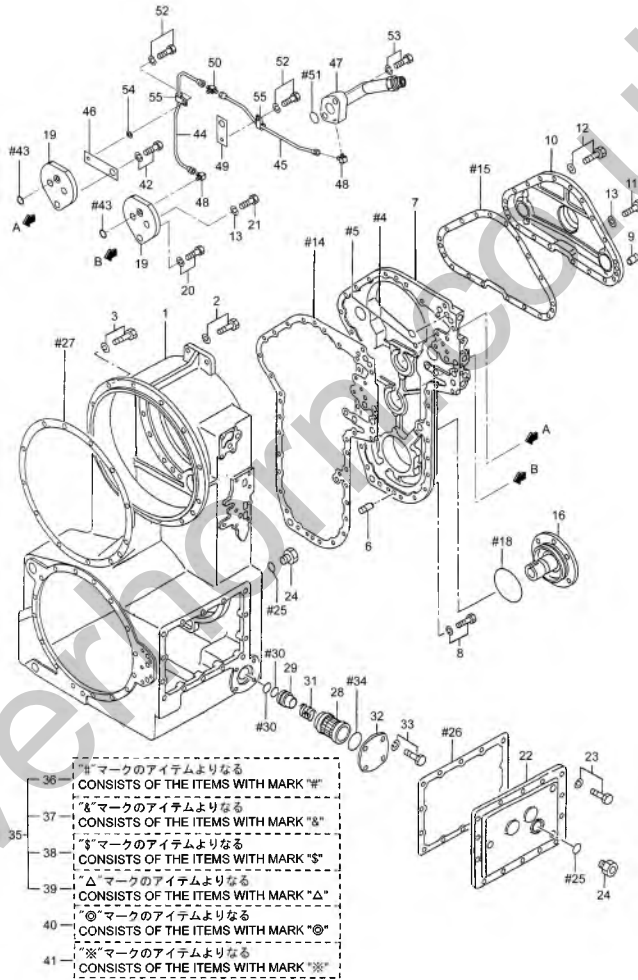

トランスミッション ケース、カバー (ソノ 1)  
TRANSMISSION CASE & COVER  
(PART-1)

見出 番号 REF. NO.	部品番号 PART NO.	代 替 R / P 定 規 S C E N A R I O Q G	部品名称 および 記事・仕様記号 PART NAME & DESCRIPTION		個 数 Q T Y	型式および適用号機 MODEL & APPLICABLE SERIAL NO.				管 区 M / R 新 規 V R D
						MG500S				
						FROM@-	-@UPTO			
1	60725-50100		HOUSING ASSY. T/W		1					
2	F2006-10050		BOLT, W/WASHER	B/W	2					A
3	F2005-10035		BOLT, W/WASHER	B/W	10					A
4	F3150-02400		O-RING		11					A
5	F3153-03000		O-RING		5					A
6	F2846-14000		PIN, DOWEL		3					A
7	60725-40200		T/F COVER ASSY		1					
8	F1805-12030		BOLT, W/WASHER	B/W	21					A
9	F2846-14000		PIN, DOWEL		2					A
10	60725-20300		COVER		1					
11	F1035-12100		BOLT		10					A
12	F1805-12030		BOLT, W/WASHER	B/W	6					A
13	F2515-12000		WASHER, SPRING		14					A
14	60725-00501		GASKET, T/F COVER		1					
15	60725-00601		GASKET, PUMP COVER		1					
16	60725-01401		SHAFT, OUTPUT, T/F		1					
17	F1805-12030		BOLT, W/WASHER	B/W	6					A
18	F3153-20000		O-RING		1					A
19	60725-27300		PLATE, LOCK		2					
20	F1805-12025		BOLT, W/WASHER	B/W	1					A
21	F1035-12030		BOLT		4					A
22	60725-09800		COVER, SIDE		1					
23	F1805-12030		BOLT, W/WASHER	B/W	14					A
24	58316-14200		PLUG, MAGNET		2					A
25	58316-02700		RING, SEAL		2					
26	62625-07701		GASKET, SIDE COVER		1					
27	62626-03401		GASKET		1					A
28	69332-00600		STRAINER, SUCTION		1					
29	69332-00701		SPACER, SUCTION		1					
30	F3153-05500		O-RING		2					A
31	69332-00800		SPRING, SUCTION		1					
32	69332-10900		COVER, SUCTION		1					
33	F1805-10025		BOLT, W/WASHER	B/W	4					A
34	F3153-12500		O-RING		1					A
35	60725-10058		OVERHAUL KIT		1					
36	60725-10068		SEAL KIT, T/W	CONSISTS OF "#"	1					
37	60725-00078		PLATE KIT, FRICTION	CONSISTS OF "&"	1					
38	60725-10088		BEARING KIT, T/W	CONSISTS OF "\$"	1					
39	60725-20098		REPAIR KIT, T/W	CONSISTS OF "△"	1					
40	60725-20048		PLANETARY KIT, SPEED	CONSISTS OF "◎"	1					
41	60725-10028		PLANETARY KIT, F&R	CONSISTS OF "※"	1					
42	F1805-12030		BOLT, W/WASHER	B/W	1					A
43	48605-53901		RUBBER, PACKING		2					
44	60726-16800		PIPE, LUB A		1					
45	60726-16900		PIPE, LUB B		1					
46	60726-17100		PLATE, LOCK		1					
47	63801-01900		PIPE, T/W INLET		1					
48	34407-22900		CONNECTOR		2					
49	60425-05700		PLATE		1					
50	60425-08800		CONNECTOR		1					

25-01

トランスミッション ケース、カバー (ソノ 1)  
TRANSMISSION CASE & COVER  
(PART-1)

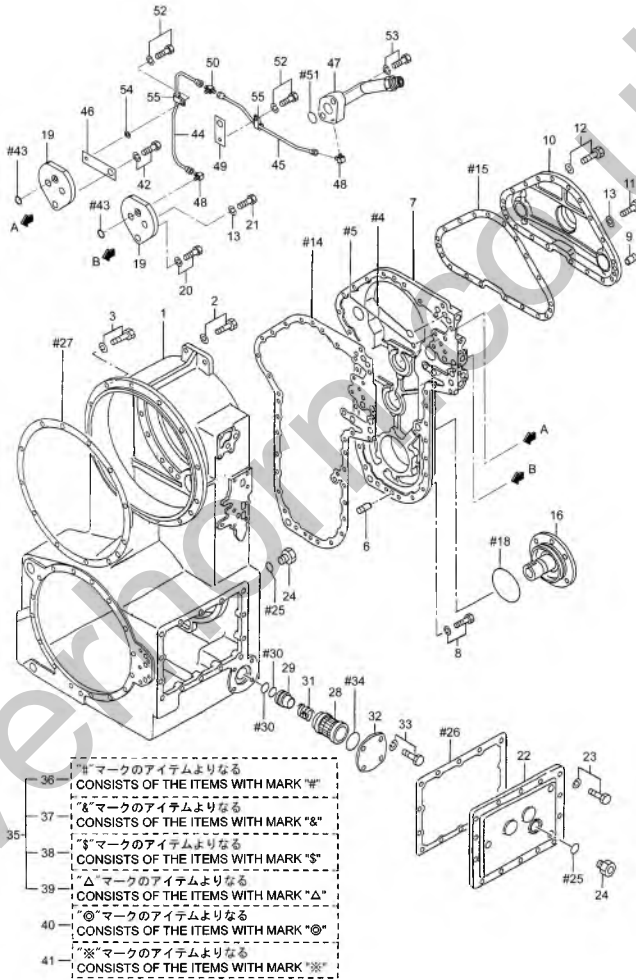

25-01

トランスミッション ケース、カバー (ソノ 1)  
TRANSMISSION CASE & COVER  
(PART-1)

- 73 -

見出 番号 REF. -NO.	部品番号 PART NO.	代 替 番 号 R / P 記 号 S C E N E S E G G	部品名称 および 記事・仕様記号 PART NAME & DESCRIPTION		個 数 Q T Y	型式および適用機種 MODEL & APPLICABLE SERIAL NO.				番 区 M / R 新 規 V R D
						MG500S				
						FROM-	-@UPTO			
51	05500-31030		O-RING		1					
52	F1806-06012		BOLT. W/WASHER	B/W	2					A
53	F1805-10035		BOLT. W/WASHER	B/W	2					A
54	F2500-08000		WASHER. PLAIN		1					A
55	F2882-05000		CLIP		2					A

トランスミッション ケース、カバー (ソノ 2)  
TRANSMISSION CASE & COVER  
(PART-2)

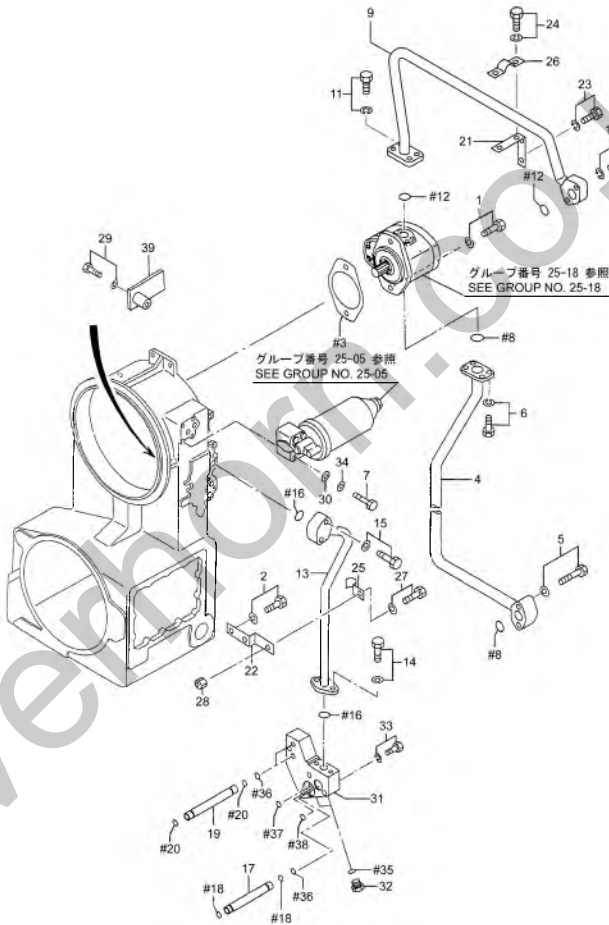

トランスミッション ケース、カバー (ソノ 2)  
TRANSMISSION CASE & COVER  
(PART-2)

見出 番号 REF. -NO.	部品番号 PART NO.	代 替 R / P 定 規 S C E N A R I O Q G	部品名称 および 記事・仕様記号 PART NAME & DESCRIPTION		個 数 Q T Y	型式および適用号機 MODEL & APPLICABLE SERIAL NO.				管 区 M / R 新 規 V R D
						MG500S				
						FROM@-	-@UPTO			
1	F1805-12030		BOLT, W/WASHER	B/W	2					A
2	F1805-10020		BOLT, W/WASHER	B/W	2					A
3	60725-00702		GASKET, PUMP		1					
4	60726-10300		PIPE		1					
5	F1805-10070		BOLT, W/WASHER	B/W	2					A
6	F2005-10025		BOLT, W/WASHER	B/W	4					A
7	F1035-12080		BOLT		4					A
8	F3150-03800		O-RING		2					A
9	60726-20400		PIPE, MAIN		1					
10	F1805-10055		BOLT, W/WASHER	B/W	2					A
11	F2005-10025		BOLT, W/WASHER	B/W	4					A
12	F3153-03000		O-RING		2					A
13	60726-00500		PIPE, MAIN		1					
14	F1805-10025		BOLT, W/WASHER	B/W	2					A
15	F1805-10055		BOLT, W/WASHER	B/W	2					A
16	F3153-03000		O-RING		2					A
17	60726-00600		PIPE, O-RING TYPE		1					
18	F3150-02200		O-RING		2					A
19	60726-00800		PIPE, O-RING TYPE		2					
20	F3150-01500		O-RING		4					A
21	60726-03600		SUPPORT, PIPE		1					
22	60726-11200		PLATE		1					
23	F1805-10016		BOLT, W/WASHER	B/W	2					A
24	F1805-08012		BOLT, W/WASHER	B/W	2					A
25	60726-11300		CLAMP		1					A
26	60726-03700		CLAMP		1					A
27	F1805-10025		BOLT, W/WASHER	B/W	1					A
28	F2300-10000		NUT, LOCK		1					
29	F1805-10045		BOLT, W/WASHER	B/W	1					A
30	F2500-12000		WASHER, PLAIN		4					A
31	60726-11600		CONNECTOR		1					
32	05530-20200		PLUG		2					A
33	F1805-10065		BOLT, W/WASHER	B/W	4					A
34	F2515-12000		WASHER, SPRING		4					A
35	F3150-01100		O-RING		2					A
36	F3150-02400		O-RING		2					A
37	F3150-04600		O-RING		1					A
38	F3153-03000		O-RING		1					A
39	60726-02900		CLAMP		1					A

トランスミッション ケース、カバー (ソノ 3)  
TRANSMISSION CASE & COVER  
(PART-3)

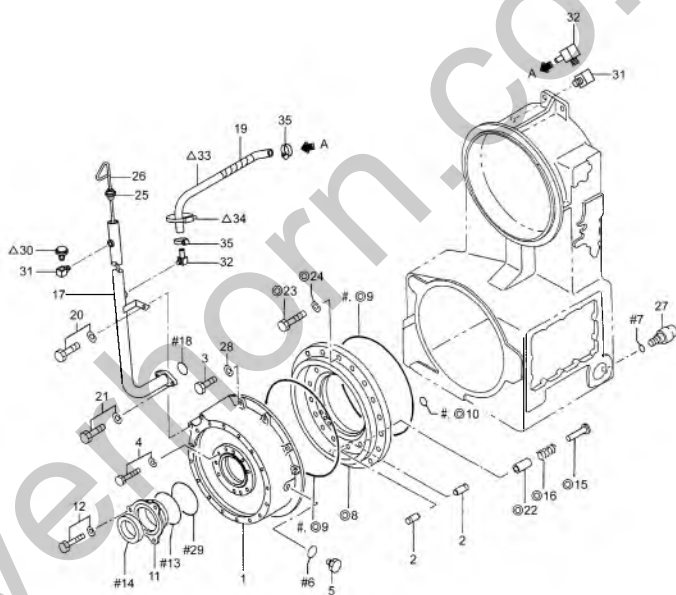

トランスミッション ケース、カバー (ソノ 3)  
TRANSMISSION CASE & COVER  
(PART-3)

見出 番号 REF. -NO.	部品番号 PART NO.	代 替 R / P 定 規 S C E N A R I O G G	部品名称 および 記事・仕様記号 PART NAME & DESCRIPTION	個 数 Q T Y	型式および適用号機 MODEL & APPLICABLE SERIAL NO.				管 区 M / R 新 規 V R D
					MG500S				
					FROM-	-@UPTO			
1	60725-10400		HOUSING, OUTPUT	1					
2	F2846-14000		PIN, DOWEL	1					A
3	F1035-12075		BOLT	16					A
4	F2005-12045		BOLT, W/WASHER	3					A
5	05530-20200		PLUG	1					A
6	F3150-01100		O-RING	1					A
7	F4202-12000		GASKET	1					A
8	60725-13100		PLATE	1					A
9	05563-76387		O-RING	2					A
10	F3150-01600		O-RING	1					A
11	60725-17600		SLEEVE, OUTPUT	1					A
12	F1805-12030		BOLT, W/WASHER	3					A
13	F3153-12000		O-RING	1					A
14	60725-08300		SEAL, OIL	1					A
15	60725-28600		SEAT, SPRING	5					A
16	60325-05800		SPRING, RETURN	5					A
17	60726-20200		PIPE, LEVEL GAGE	1					A
18	F3150-03800		O-RING	1					A
19	05379-25060		TUBE, SPIRAL	1					A
20	F1805-12020		BOLT, W/WASHER	1					A
21	F1805-10030		BOLT, W/WASHER	2					A
22	62625-16800		PIN, SPRING	5					A
23	62625-27300		BOLT	14					A
24	F2515-12000		WASHER, SPRING	14					A
25	62626-06800		PLUG	1					A
26	60726-04900		GAGE, OIL LEVEL	1					A
27	MH037791		PLUG, SCREW	1					A
28	F2515-12000		WASHER, SPRING	16					A
29	F3153-13500		O-RING	1					A
30	91524-01900		BREATHER	1					A
31	62625-29500		CONNECTOR	2					
32	91875-07200		ELBOW	2					
33	F4010-12120		HOSE, RUBBER	1					
34	08685-00600		TY-RAP	2					
35	05317-50251		CLAMP	2		@00015			
	05317-50221	3 1	CLAMP	2					V



25-04 トランスミッション ケース、カバー (ソノ 4)  
TRANSMISSION CASE & COVER  
(PART-4)

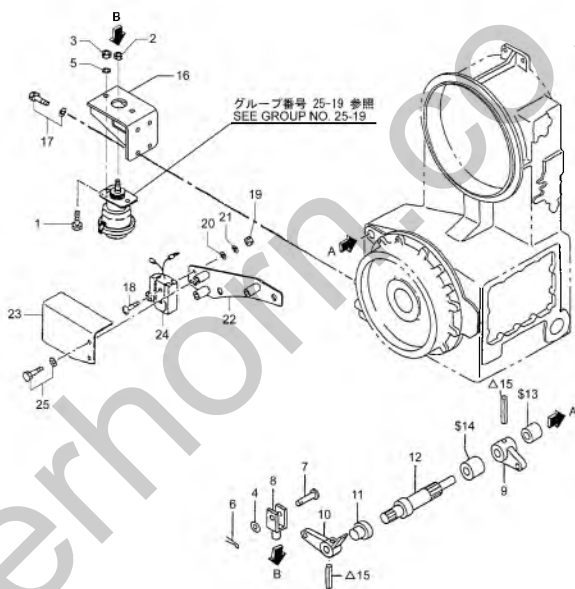

トランスミッション ケース、カバー (ソノ 4)  
TRANSMISSION CASE & COVER  
(PART-4)

見出 番号 REF. -NO.	部品番号 PART NO.	代 替 R / P 定 製 品 番 号 S C E N E R I O S	部品名称 および 記事・仕様記号 PART NAME & DESCRIPTION	個 数 Q T Y	型式および適用号機 MODEL & APPLICABLE SERIAL NO.				番 区 M V / R D
					MG500S				
					FROM@-	-@UPTO			
1	F1035-14035		BOLT	2					A
2	F2300-12000		NUT	1					A
3	F2300-14000		NUT	2					A
4	F2500-12000		WASHER, PLAIN	1					A
5	F2515-14000		WASHER, SPRING	2					A
6	F2841-30025		PIN, SPLIT	1					A
7	F2855-12038		PIN, CLEVIS	1					A
8	F2925-12048		CLEVIS	1					A
9	60725-18801		LEVER, INNER	1					A
10	60725-28900		LEVER, OUTER	1					A
11	60725-09200		SPACER	1					A
12	60725-09100		SHAFT	1					A
13	05643-06200		BEARING, NEEDLE	1					A
14	05643-07100		BEARING, NEEDLE	1					A
15	F2850-04020		PIN, SPRING	2					A
16	60726-00101		BRACKET, ROTOCHAMBER	1					A
17	F1805-12030		BOLT, W/WASHER	4					A
18	F1600-04030		SCREW, MACHINE	2					A
19	F2300-04000		NUT	2					A
20	F2500-04000		WASHER, PLAIN	2					A
21	F2515-04000		WASHER, SPRING	2					A
22	60726-02600		BRACKET, SWITCH	1					A
23	60726-02700		COVER, SWITCH	1					A
24	65504-01901		SWITCH, MICRO	1					A
25	F1805-08014		BOLT, W/WASHER	2					A

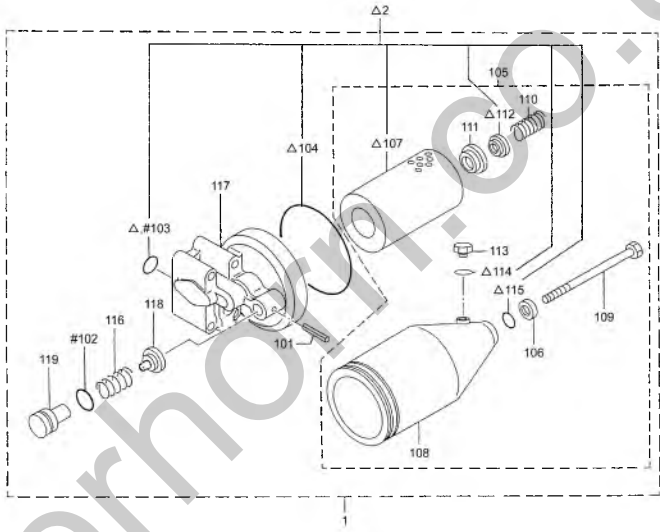

見出 番号 REF. -NO.	部品番号 PART NO.	代 替 R / P 家 記 順 号 S C E N E P G G	部品名称 および 記事・仕様記号 PART NAME & DESCRIPTION	個 数 Q T Y	型式および適用号機 MODEL & APPLICABLE SERIAL NO.			番 区 M V / R D 新 規
					MG500S			
					FROM-	-@UPTO		
1	69331-20030	3 1	FILTER ASSY, OIL	1		@00056		A
1 01	69331-30030		FILTER ASSY, OIL	1				A
1 02	F2850-05016		PIN, SPRING	1				A
1 03	F3150-01500		O-RING	1				A
1 04	F3150-02400		O-RING	2				A
1 05	05563-70429		O-RING	1				A
1 06	69331-00018		FILTER KIT, OIL	1				A
1 07	F2500-16000		WASHER, PLAIN	1				A
1 08	69331-09700		ELEMENT	1				A
1 09	69332-03100		CASE	1				A
1 10	69332-03200		BOLT, CENTER	1				A
1 11	69332-03300		SPRING	1				A
1 12	69332-03400		PLATE	1				A
1 13	69332-03500		GASKET	1				A
1 14	69332-03600		PLUG	1				A
1 15	69332-03700		O-RING	1				A
1 16	69332-03800		O-RING	1				A
1 17	69332-07100		SPRING	1				A
1 18	69332-10100	3 1	BRACKET	1		@00056		V
1 19	69332-20100		BRACKET	1				
2	69332-16800		SPOOL	1				A
	69332-16900		PLUG	1				A
	69331-00028		FILTER KIT, OIL	1				A

25-06

トランスミッション シャフト、ギヤ (ソノ 1)  
TRANSMISSION SHAFT & GEAR  
(PART-1)

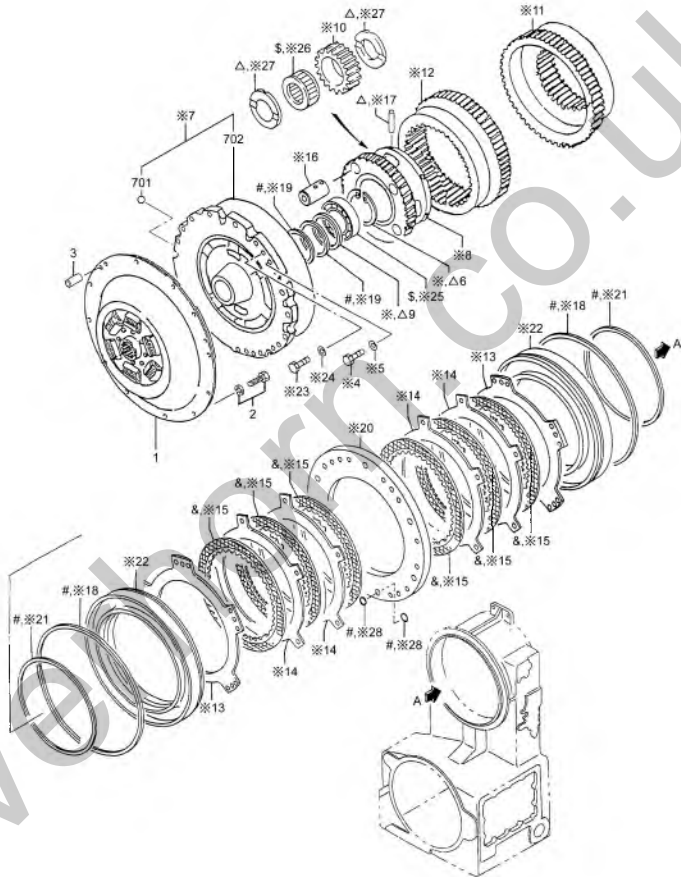

トランスミッション シャフトキヤ (ソノ 1)  
TRANSMISSION SHAFT & GEAR  
(PART-1)

見出 番号 REF. -NO.	部品番号 PART NO.	代 替 R / P 定 額 S C E N A R I O G G	部品名称 および 記事・仕様記号 PART NAME & DESCRIPTION		個 数 Q T Y	型式および適用号機 MODEL & APPLICABLE SERIAL NO.				管 区 M / R 新 規 V R D
						MG500S				
						FROM-	-@UPTO			
1	60725-00800		DISK ASSY, DAMPER		1					
2	F2006-10025		BOLT, W/WASHER	B/W	12					A
3	F2846-10000		PIN, DOWEL		2					A
4	F1035-12100		BOLT		2					A
5	F2515-12000		WASHER, SPRING		2					A
6	F3200-08000		RING, SNAP		1					A
7	60725-12400		HOUSING ASSY, PISTON		1					A
7 01	F8000-14000		BALL, STEEL		3					A
7 02	60725-12411		HOUSING, PISTON		1					
8	60725-03201		CARRIER, PLANET		1					
9	05616-10110		RING, RETAINING		1					
10	60725-14701		GEAR, PLANET	Z=26	4					
11	60725-05601		GEAR, RING	Z=88	1					
12	60725-05701		GEAR, RING	Z=88	1					
13	60725-06800		PLATE, PRESSURE		2					
14	60725-06900		PLATE, MATING		4					
15	60725-07100		PLATE, FACING		6					
16	62625-14803		PIN ASSY, PLANET		4					
17	62625-19400		PIN, SPRING		4					A
18	69321-11600		SEAL, PISTON, OUTER		2					
19	69331-12100		RING, SEAL		2					
20	60726-04500		PLATE, STOPPER		1					
21	69331-17200		SEAL, PISTON, INNER		2					
22	69331-17301		PISTON		2					A
23	92725-15800		BOLT		14					A
24	F2515-12000		WASHER, SPRING		14					A
25	05640-06916		BEARING, BALL		1					A
26	05643-06800		BEARING, NEEDLE		4					A
27	62625-25100		WASHER, THRUST		8					A
28	F3150-01600		O-RING		4					A

トランスミッション シャフト,ギヤ (ソノ 2)  
TRANSMISSION SHAFT & GEAR  
(PART-2)

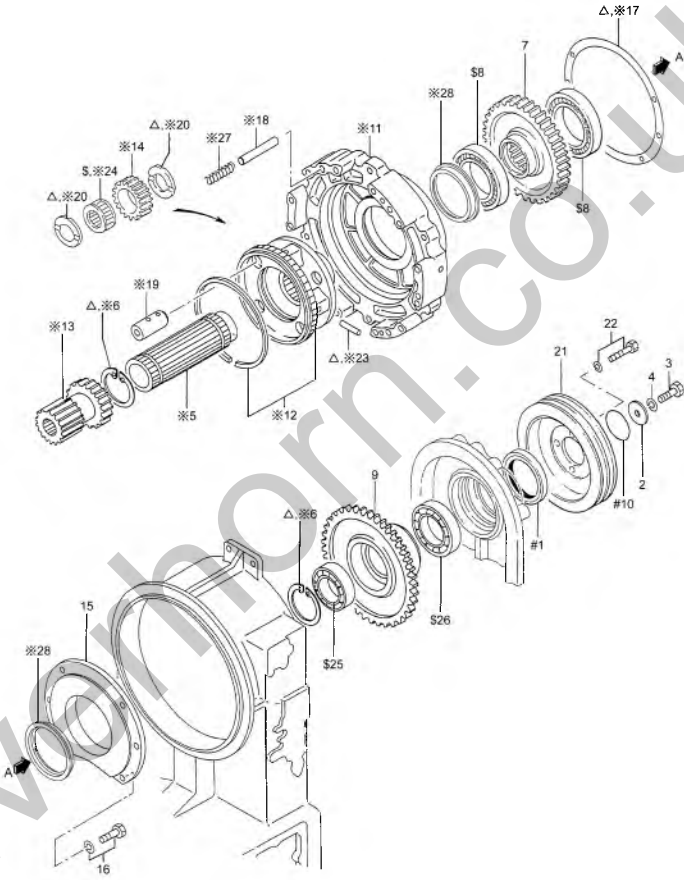

トランスミッション シャフトキヤ (ソノ 2)  
TRANSMISSION SHAFT & GEAR  
(PART-2)

見出 番号 REF. -NO.	部品番号 PART NO.	代 替 R / P 定 規 番 号 S C E N E R I O S	部品名称 および 記事・仕様記号 PART NAME & DESCRIPTION	個 数 Q T Y	型式および適用号機 MODEL & APPLICABLE SERIAL NO.				番 区 M / R 新 規 V R D
					MG500S				
					FROM@-	-@UPTO			
1	F3019-10023		SEAL, OIL	1					A
2	60726-01400		PLATE, LOCK	1					A
3	F1155-16035		BOLT	1					A
4	F2515-16000		WASHER, SPRING	1					A
5	60725-01201		SHAFT, INPUT T/F	1					A
6	F3200-07500		RING, SNAP	2					A
7	60725-21500		GEAR, INPUT	1					A
8	05644-02700		BEARING, TAPER ROLLER	2					A
9	60725-11901		GEAR, PUMP, DRIVE	1					A
10	F3150-03000		O-RING	1					A
11	60725-22500		HOUSING ASSY, PISTON	1					A
12	60725-23300		CARRIER ASSY, PLANET	1					A
13	60725-13900		GEAR, SUN, F&R	1					A
14	60725-14801		GEAR, PLANET	4					A
15	60725-15500		RETAINER, BEARING	1					A
16	F1805-12030		BOLT, W/WASHER	6					A
17	60725-06400		SHIM SET	1					A
18	60725-06600		PIN, CLUTCH	6					A
19	62625-14803		PIN ASSY, PLANET	4					A
20	62625-25100		WASHER, THRUST	8					A
21	62625-08900		PULLEY	1					A
22	F1035-10025		BOLT	4					A
23	62625-19400		PIN, SPRING	4					A
24	05643-02300		BEARING, NEEDLE	4					A
25	F8004-06013		BEARING, BALL	1					A
26	05640-06920		BEARING, BALL	1					A
27	60726-02800		SPRING, RETURN	12					A
28	60726-08100		SPACER	2					A



25-08

トランスミッション シャフト、ギヤ (ソノ 3)  
TRANSMISSION SHAFT & GEAR  
(PART-3)

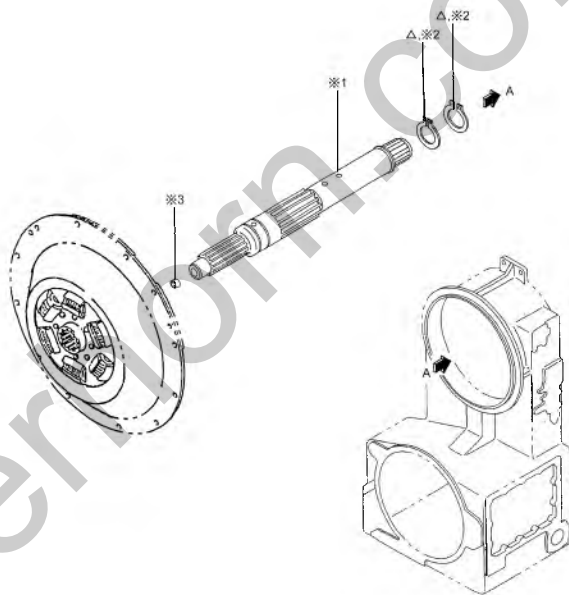

25-08

トランスミッション シャフトギヤ (ソノ 3)  
 TRANSMISSION SHAFT & GEAR  
 (PART-3)

- 87-

見出 番号 REF. -NO.	部品番号 PART NO.	代 替 番 号 R / P	定 規 番 号 S C E N E Q G	部品名称 および 記事・仕様記号 PART NAME & DESCRIPTION	個 数 Q T Y	型式および適用号機 MODEL & APPLICABLE SERIAL NO.			管 区 M / R	新 規 V R D
						MG500S				
						FROM-	-@UPTO			
1	60726-09800			SHAFT, INPUT	1					
2	F3200-05200			RING, SNAP	2					A
3	04826-21600			GAP, SEALING	1					A

トランスミッション シャフト,キヤ (ソノ 4)  
TRANSMISSION SHAFT & GEAR  
(PART-4)

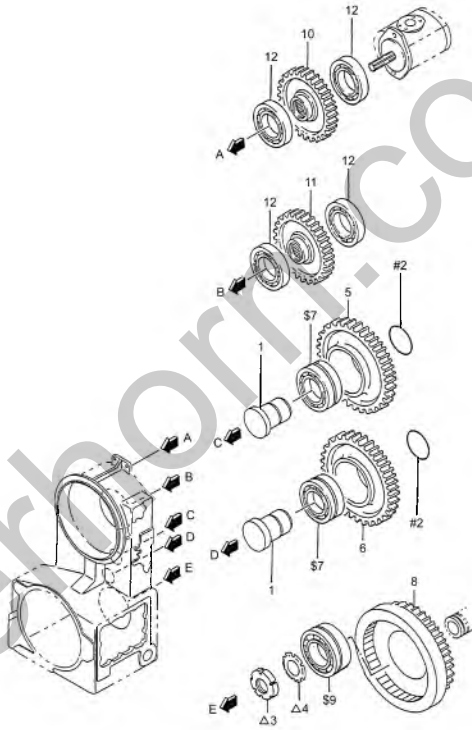

25-09

トランスミッション シャフト、ギヤ (ソノ 4)  
TRANSMISSION SHAFT & GEAR  
(PART-4)

- 89 -

見出 番号 REF. -NO.	部品番号 PART NO.	代 替 R / P 定 額 時 S C E N E S P P G G	部品名称 および 記事・仕様記号 PART NAME & DESCRIPTION		個 数 Q T Y	型式および適用号種 MODEL & APPLICABLE SERIAL NO.				管 区 M / R 新 規 V R D
						MG500S				
						FROM@-	-@UPTO			
1	60725-21300		SHAFT, IDLER		2					
2	F3153-06000		O-RING		2					
3	00210-78010		NUT		1					A
4	00305-78010		WASHER, LOCK		1					A
5	60725-31600		GEAR, IDLER T/F	Z=34	1					
6	60725-31700		GEAR, IDLER T/F	Z=35	1					
7	60726-05300		BEARING, T/F		2					
8	60725-31800		GEAR, OUTPUT	Z=34	1					
9	60726-05400		BEARING, T/F		1					
10	60725-02100		GEAR, PUMP, DRIVEN	Z=38	1					
11	60726-01700		GEAR, PUMP, DRIVEN	Z=38	1					
12	F8006-06206		BEARING, BALL		4					A

2013-03-22

160660-01

トランスミッション シャフト、ギヤ (ソノ 5)  
TRANSMISSION SHAFT & GEAR  
(PART-5)

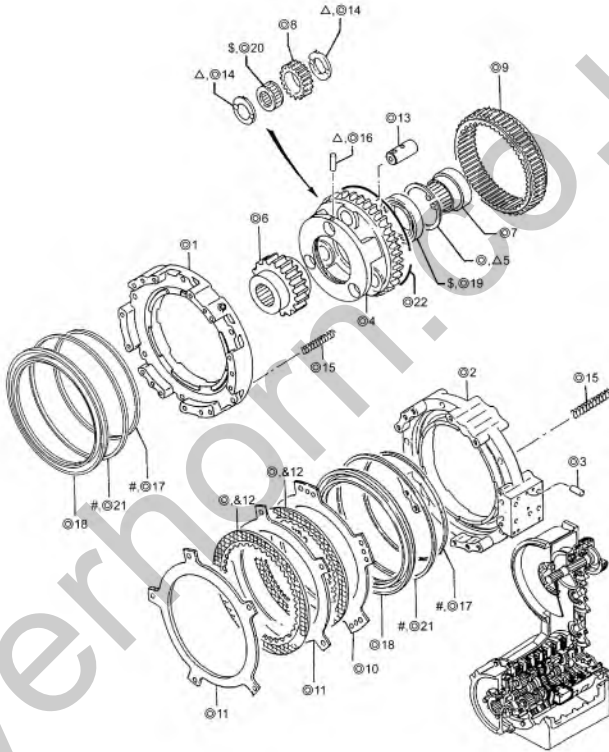

トランスミッション シャフトキヤ (ソノ 5)  
TRANSMISSION SHAFT & GEAR  
(PART-5)

見出 番号 REF. -NO.	部品番号 PART NO.	代 替 R / P 定 額 番 号 S C E N E G G	部品名称 および 記事・仕様記号 PART NAME & DESCRIPTION		個 数 Q T Y	型式および適用号機 MODEL & APPLICABLE SERIAL NO.				番 区 M V / R D
						MG500S				
						FROM-	-@UPTO			
1	60725-12703		HOUSING ASSY, PISTON		1					A
2	60725-22802		HOUSING ASSY, PISTON		1					
3	F2846-08000		PIN, DOWEL		1					A
4	60725-23600		CARRIER, PLANET		1					
5	F3202-10000		RING, SNAP		1					A
6	60725-04300		GEAR, SUN	Z=44	1					
7	60725-04600		SPACER		1					
8	60725-15302		GEAR, PLANET	Z=21	3					
9	60725-15800		GEAR, RING	Z=85	1					
10	60725-06800		PLATE, PRESSURE		1					
11	60725-06900		PLATE, MATING		2					
12	60725-07100		PLATE, FACING		2					
13	62625-14803		PIN ASSY, PLANET		3					
14	62625-25100		WASHER, THRUST		6					A
15	62625-06500		SPRING		24					A
16	62625-19400		PIN, SPRING		3					A
17	69331-17200		SEAL, PISTON, INNER		2					
18	69331-17301		PISTON		2					A
19	05640-06914		BEARING, BALL		1					A
20	05643-02200		BEARING, NEEDLE		3					A
21	69321-11600		SEAL, PISTON, OUTER		2					
22	69331-16800		RING, SNAP		1					A

トランスミッション シャフト、ギヤ (ソノ 6)  
TRANSMISSION SHAFT & GEAR  
(PART-6)

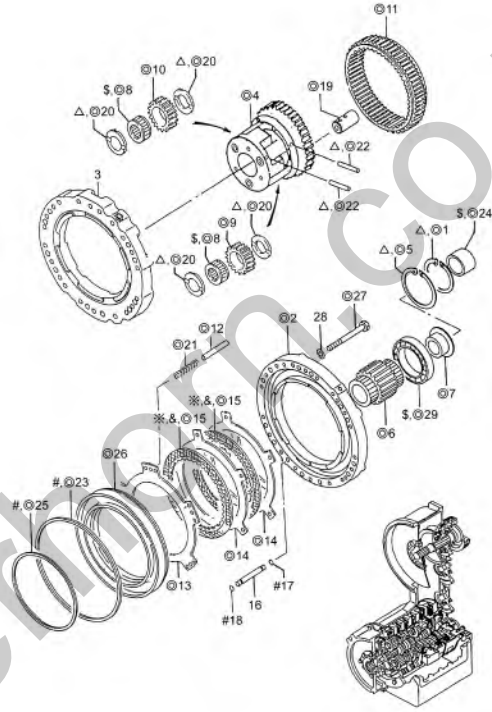

トランスミッション シャフトキヤ (ソノ6)  
 TRANSMISSION SHAFT & GEAR  
 (PART-6)

見出 番号 REF. -NO.	部品番号 PART NO.	代 替 R / P	定 型 番 号 S C E N E S / P Q G	部品名称 および 記事・仕様記号 PART NAME & DESCRIPTION	個 数 Q T Y	型式および適用号機 MODEL & APPLICABLE SERIAL NO.				管 区 M V / R D
						MG500S				
						FROM-	-@	UPTO		
1	F3200-05500			RING, SNAP	1					A
2	60725-12600			FRONT SUPPORT PLATE	1					
3	60725-12703			HOUSING, PISTON	1					A
4	60725-33400			CARRIER, PLANET	1					
5	F3202-10000			RING, SNAP	1					A
6	60725-14100			GEAR, SUN	1					
7	60725-04500			SPACER	1					
8	05643-02300			BEARING	6					A
9	60725-14901			GEAR, PLANET	3					
10	60725-25100			GEAR, PLANET	3					
11	60725-15800			GEAR, RING	1					
12	60725-06700			PIN, CLUTCH	6					
13	60725-06800			PLATE, PRESSURE	1					
14	60725-06900			PLATE, MATING	2					
15	60725-07100			PLATE, FACING	2					
16	60726-10700			PIPE, O-RING TYPE	2					
17	F3150-01400			O-RING	2					A
18	F3150-01500			O-RING	2					A
19	62625-14803			PIN ASSY, PLANET	6					
20	62625-25100			WASHER, THRUST	12					A
21	62625-06500			SPRING	12					A
22	62625-19400			PIN, SPRING	6					A
23	69321-11600			SEAL, PISTON, OUTER	1					
24	69331-06300			BUSHING	1					
25	69331-17200			SEAL, PISTON, INNER	1					
26	69331-17301			PISTON	1					A
27	92725-15800			BOLT	14					A
28	F2515-12000			WASHER, SPRING	14					A
29	05640-06914			BEARING, BALL	1					A



トランスミッション シャフト、ギヤ (ソノ 7)  
TRANSMISSION SHAFT & GEAR  
(PART-7)

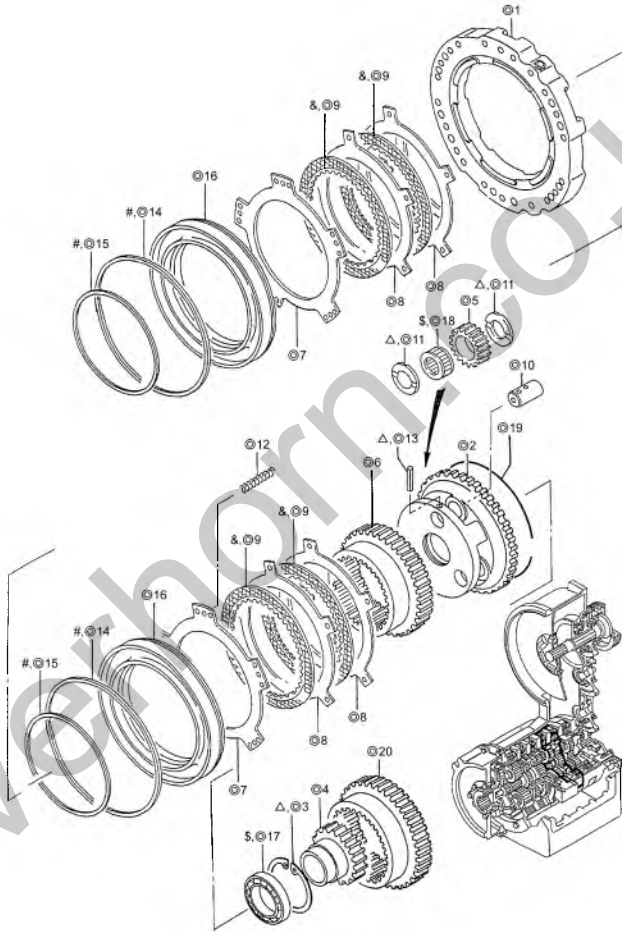

トランスミッション シャフト、ギヤ (ソノ 7)  
 TRANSMISSION SHAFT & GEAR  
 (PART-7)

見出番号 REF. -NO.	部品番号 PART NO.	代 替 R / P	定 規 番 号 S C E N E R Y	部品名称 および 記事・仕様記号 PART NAME & DESCRIPTION	個 数 Q T Y	型式および適用号機 MODEL & APPLICABLE SERIAL NO.				番 区 M / R	新 規 V R D
						MG500S					
						FROM-	-@UPTO				
1	60725-12703			HOUSING ASSY, PISTON	1						A
2	60725-13500			CARRIER, PLANET	1						
3	F3202-10000			RING, SNAP	1						A
4	60725-14200			GEAR, SUN	1						
5	60725-15201			GEAR, PLANET	3						
6	60725-15900			GEAR, RING	1						
7	60725-06800			PLATE, PRESSURE	2						
8	60725-06900			PLATE, MATING	4						
9	60725-07100			PLATE, FACING	4						
10	62625-14803			PIN ASSY, PLANET	3						
11	62625-25100			WASHER, THRUST	6						A
12	62625-06500			SPRING	12						A
13	62625-19400			PIN, SPRING	3						A
14	69321-11600			SEAL, PISTON, OUTER	2						
15	69331-17200			SEAL, PISTON, INNER	2						
16	69331-17301			PISTON, CLUTCH	2						A
17	05640-06914			BEARING, BALL	1						A
18	05643-02200			BEARING, NEEDLE	3						A
19	69331-16800			RING, SNAP	1						A
20	60726-07800			GEAR, RING	1						

トランスミッション シャフト、ギヤ (ソノ 8)  
TRANSMISSION SHAFT & GEAR  
(PART-8)

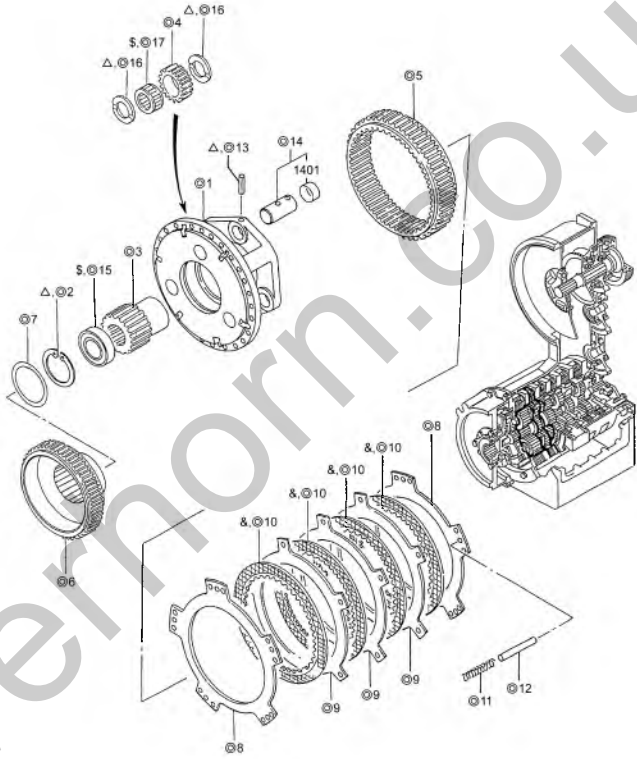

トランスミッション シャフトキヤ (ソノ 8)  
TRANSMISSION SHAFT & GEAR  
(PART-8)

見出 番号 REF. -NO.	部品番号 PART NO.	代 替 R / P 家 記 号 S C E N E P G G	部品名称 および 記事・仕様記号 PART NAME & DESCRIPTION		個 数 Q T Y	型式および適用機種 MODEL & APPLICABLE SERIAL NO.				番 区 M / R D 新 規 V R D
						MG500S				
						FROM@-	-@UPTO			
1	60725-23700		CARRIER, PLANET		1					
2	F3202-11500		RING, SNAP		1					A
3	60725-14400		GEAR, SUN	Z=28	1					
4	60725-15401		GEAR, PLANET	Z=29	3					
5	60725-16100		GEAR, RING	Z=86	1					
6	60725-16300		HUB, CLUTCH		1					
7	05616-10185		RING, RETAINING		1					
8	60725-06800		PLATE, PRESSURE		2					
9	60725-06900		PLATE, MATING		3					
10	60725-07100		PLATE, FACING		4					
11	62625-06500		SPRING		12					A
12	62625-06601		PIN, CLUTCH		6					A
13	62625-19400		PIN, SPRING		3					A
14	69331-15702		PIN ASSY, PLANET		3					
14 01	F5014-14000		CAP, SEALING		3					A
15	F8004-06015		BEARING, BALL		1					A
16	69331-17101		WASHER, THRUST		6					A
17	05643-04700		BEARING, NEEDLE		3					A

25-14

トランスミッション シャフト、ギヤ (ソノ 9)  
TRANSMISSION SHAFT & GEAR  
(PART-9)

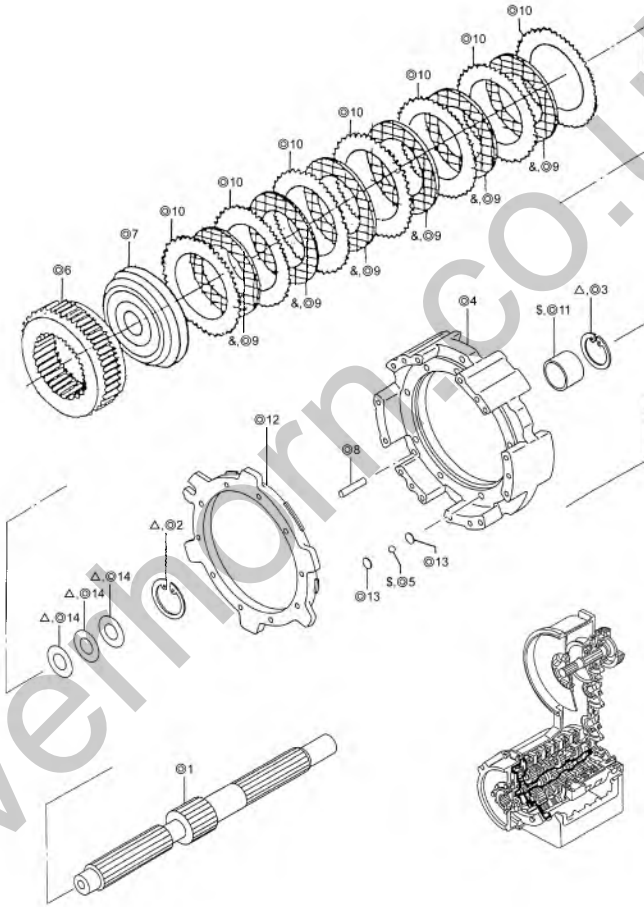

トランスミッション シャフトギヤ (ソノ 9)  
TRANSMISSION SHAFT & GEAR  
(PART-9)

見出 番号 REF. -NO.	部品番号 PART NO.	代 替 R / P 定 規 S C E N E Q G	部品名称 および 記事・仕様記号 PART NAME & DESCRIPTION	個 数 Q T Y	型式および適用号機 MODEL & APPLICABLE SERIAL NO.			管 区 M / R 新 規 V R D
					MG500S			
					FROM@-	-@UPTO		
1	60725-02200		SHAFT, MAIN	1				
2	F3200-05500		RING, SNAP	1				A
3	F3200-06000		RING, SNAP	1				A
4	60725-22900		HOUSING ASSY, BRAKE	1				
5	F8000-24000		BALL, STEEL	10				A
6	60725-26200		DRUM, CLUTCH	1				
7	60725-36500		PISTON, CLUTCH	1				
8	60725-06600		PIN, CLUTCH	5				
9	60725-07200		PLATE, FACING	6				
10	60725-17401		PLATE, MATING	7				
11	69331-06300		BUSHING	1				
12	60725-28400		PISTON, BRAKE	1				
13	60725-08500		SEAT, BALL	20				
14	60325-11400		SPRING, DISK	3				A

トランスミッション シャフト,ギヤ (ソノ 10)  
TRANSMISSION SHAFT & GEAR  
(PART-10)

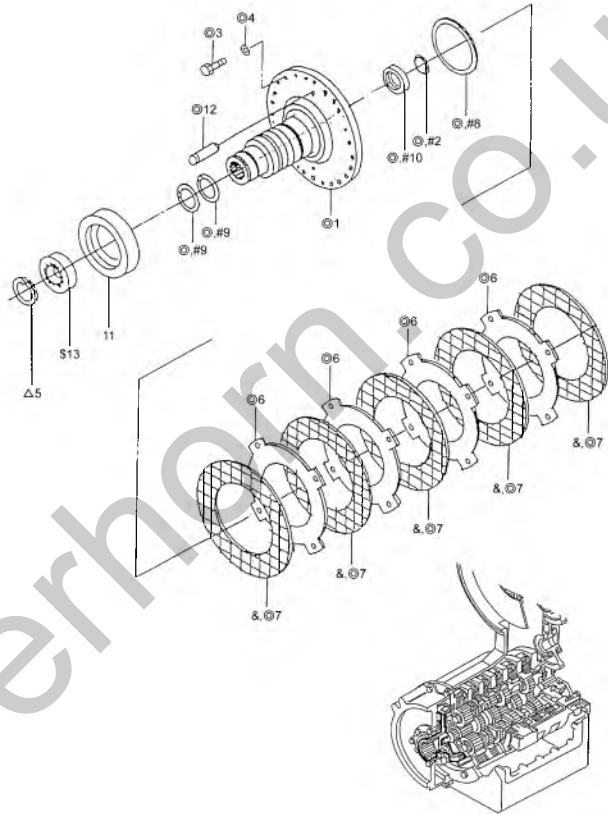

トランスミッション シャフト、ギヤ (ソノ 10)  
TRANSMISSION SHAFT & GEAR  
(PART-10)

見出 番号 REF. -NO.	部品番号 PART NO.	代 表 順 号 R S C E N P Q G	部品名称 および 記事・仕様記号 PART NAME & DESCRIPTION	個 数 Q T Y	型式および適用号機 MODEL & APPLICABLE SERIAL NO.				管 区 新 規 M V R D
					MG500S				
					FROM#-	-@UPTO			
1	60725-22300		FLANGE, OUTPUT	1					
2	05563-76137		O-RING	1					A
3	F1035-10100		BOLT	29					A
4	F2515-10000		WASHER, SPRING	29					A
5	F3200-10000		RING, SNAP	1					A
6	69331-07400		PLATE, MATING	4					
7	60725-07100		PLATE, FACING	5					
8	60725-17800		SEAL, PISTON OUTER	1					
9	60725-18200		RING, SEAL	2					
10	62625-36101		SEAL	1					A
11	60425-16601		RETAINER, BEARING	1					
12	69331-18700		PIN, CLUTCH PISTON	2					A
13	05641-02700		BEARING, BALL	1					A



レギュレータバルブ  
REGULATOR VALVE

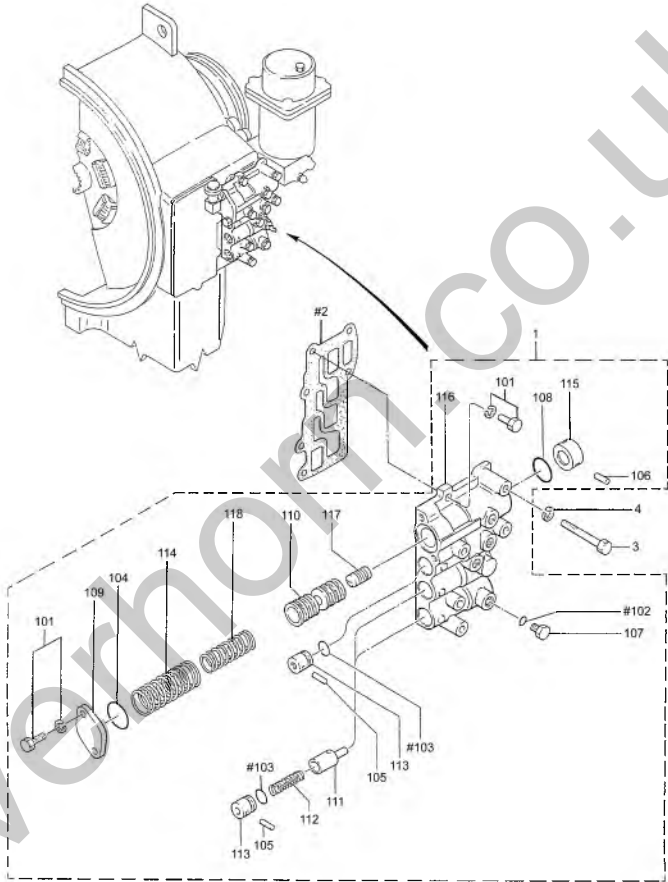

レギュレータバルブ  
REGULATOR VALVE

見出 番号 REF. -NO.	部品番号 PART NO.	代 替 R / P 配 置 S C E N E G G	部品名称 および 記事・仕様記号 PART NAME & DESCRIPTION		個 数 Q T Y	型式および適用機種 MODEL & APPLICABLE SERIAL NO.				新 規 M V R D
						MG500S				
						FROM#-	-#UPTO			
1	62628-20012		REGULATOR		1					
1 01	F1805-08025		BOLT, W/WASHER	B/W	5					A
1 02	F3150-00800		O-RING		4					A
1 03	F3150-01500		O-RING		3					A
1 04	F3150-02800		O-RING		1					A
1 05	F8001-40032		BEARING, ROLLER		3					A
1 06	F8001-40040		BEARING, ROLLER		1					A
1 07	05530-20100		PLUG		4					A
1 08	05563-70023		O-RING		1					A
1 09	58828-13702		COVER		1					
1 10	62628-00303		SPOOL		1					
1 11	62628-00600		SPOOL		2					
1 12	62628-00700		SPRING		2					A
1 13	62628-00800		PLUG ASSY		3					A
1 14	62628-01100		SPRING, MAIN		1					
1 15	62628-01201		PLUG		1					A
1 16	62628-10102		BODY, REGULATOR		1					
1 17	62628-10400		SLUG		1					
1 18	62628-10500		SPRING		1					A
2	62628-00201		GASKET, REG VALVE		1					
3	F1035-08060		BOLT		5					A
4	F2515-08000		WASHER, SPRING		5					A

トランスミッションコントロールバルブ  
TRANSMISSION CONTROL VALVE

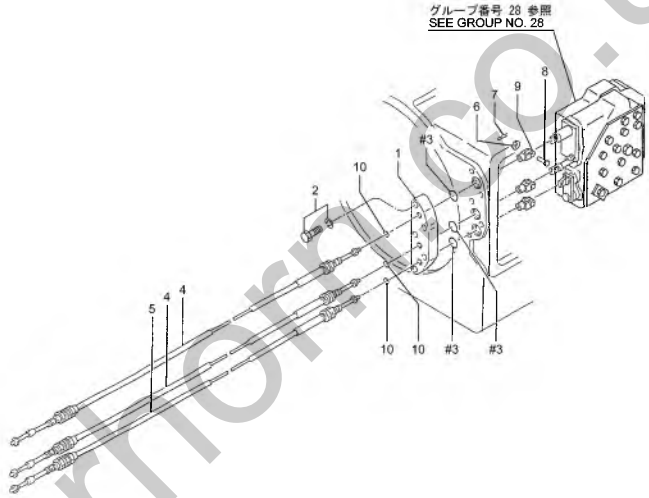

トランスミッションコントロールバルブ  
TRANSMISSION CONTROL VALVE

見出 番号 REF. -NO.	部品番号 PART NO.	代 書 R / P 記 順 号 S C E N E S G G	部品名称 および 記事・仕様記号 PART NAME & DESCRIPTION	備 数 Q T Y	型式および適用号機 MODEL & APPLICABLE SERIAL NO.				新 規 M V R D
					MG500S				
					FROM#	-@UPTO			
1	60725-19300		COVER, CABLE	1					
2	F1805-12045		BOLT	5					A
3	F3150-02200		O-RING	3					A
4	60726-11900		CABLE, CONTROL	2					
5	60726-12100		CABLE, CONTROL	1					
6	F2500-06000		WASHER, PLAIN	3					A
7	F2843-06000		PIN, SNAP	3					A
8	F2855-06018		PIN, CLEVIS	3					A
9	F2925-06024		CLEVIS	3					A
10	F3150-01000		O-RING	3					A

ギヤポンプ  
GEAR PUMP

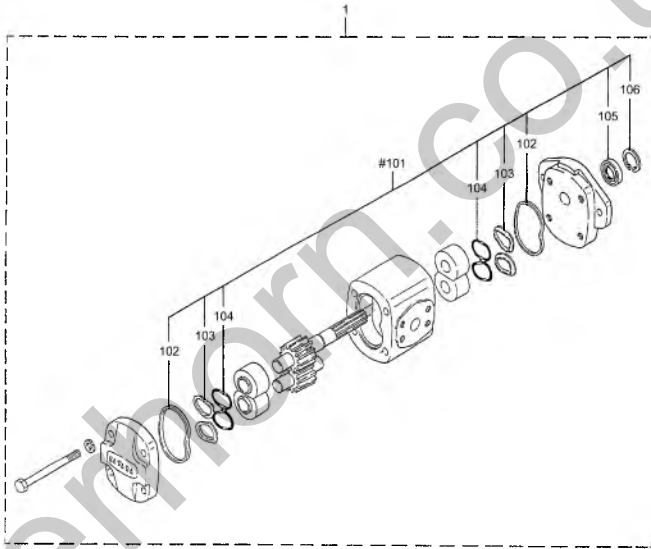

見出番号のない部品は供給不可部品です。  
PART WITHOUT REF. NO. SHALL NOT BE SUPPLIED.

キャホーン  
GEAR PUMP

見出 番号 REF. -NO.	部品番号 PART NO.	代 替 R P 食 配 S C E N P Q G G	部品名称 および 記事・仕様記号 PART NAME & DESCRIPTION	備 数 Q T Y	型式および適用号機 MODEL & APPLICABLE SERIAL NO.				新 規 M V R D
					MG500S				
					FROM-	-@UPTO			
1	60725-00010		PUMP ASSY. GEAR	1					
1 01	69331-00037		SEAL KIT	1					A
1 02	*		SEAL	2					
1 03	*		RING	4					
1 04	*		SEAL	4					
1 05	*		SEAL	1					
1 06	*		RING. SNAP	1					

スプリング チャンバ アセンブリ  
SPRING CHAMBER ASSY

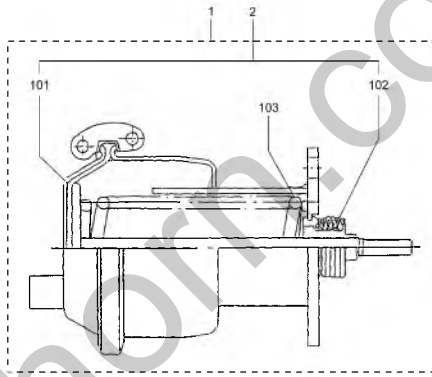

スプリング チャンバ アセンブリ  
SPRING CHAMBER ASSY

見出 番号 REF. -NO.	部品番号 PART NO.	代 替 配 列 号 R S C E N P / Q G G	部品名称 および 記事・仕様記号 PART NAME & DESCRIPTION	機 数 Q T Y	型式および適用機種 MODEL & APPLICABLE SERIAL NO.				新 規 M V R D
					MG500S				
					FROM#-	-@UPTO			
1	60725-10020		CHAMBER ASSY.ROTO	1					
1 01	60726-02300		DIAPHRAGM	1					A
1 02	60726-02400		DUST	1					
1 03	60726-12200		SPRING	1					A
2	60726-00018		REPAIR KIT	1					



セレクト ハルブ  
SELECTOR VALVE

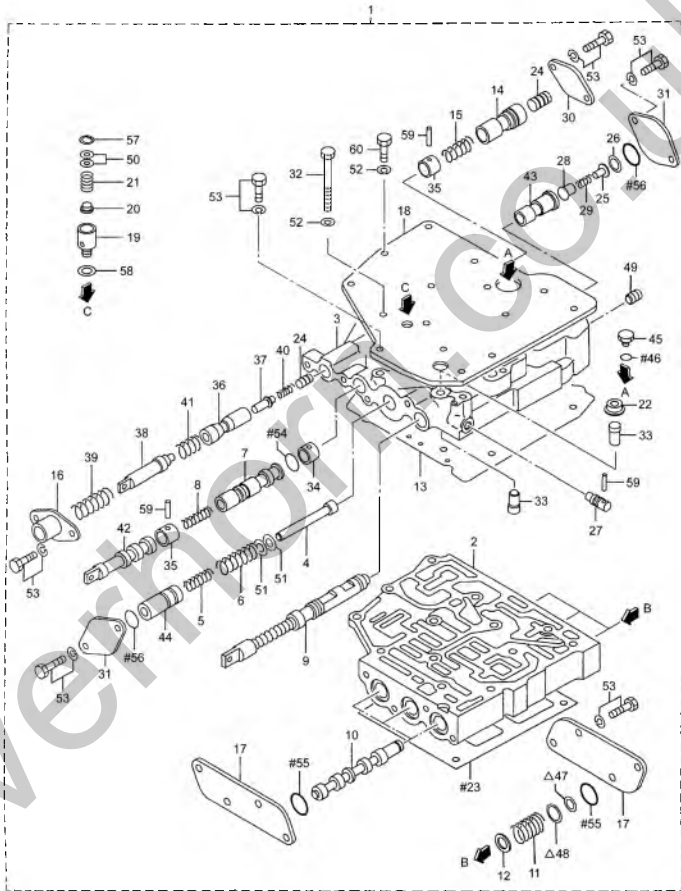

セレクトバルブ  
SELECTOR VALVE

見出 番号 REF. -NO.	部品番号 PART NO.	代 替 R / P 登 録 S E N S I V E	部品名称 および 記事・仕様記号 PART NAME & DESCRIPTION	個 数 Q T Y	型式および適用機種 MODEL & APPLICABLE SERIAL NO.				新 規 M V R D
					MG500S				
					FROM#	-@UPTO			
1	60728-20000		VALVE ASSY. SELECTOR	1					
2	60728-10103		BODY, VALVE LOWER	1					
3	60728-50200		BODY, VALVE UPPER	1					
4	60728-10500		ROD	1					
5	60728-10600		SPRING	1					A
6	60728-10700		SPRING	1					A
7	60728-10800		SPOOL	1					
8	60728-00900		SPRING, DIFFERENTIAL	1					
9	60728-11101		PLUNGER, SPEED SELECT	1					
10	60728-11501		SPOOL	3					
11	60728-01600		SPRING, SHIFT VALVE	3					
12	60728-01700		SHEAT, SPRING	6					
13	60728-21801		PLATE	1					
14	60728-01900		SPOOL	1					
15	60728-02100		SPRING	1					A
16	60728-02500		COVER, INCHING VALVE	1					
17	60728-02600		COVER, SIDE	2					
18	60728-32700		COVER, CONTROL VALVE	1					
19	60728-06600		PLUG, VALVE	1					
20	60728-07700		VALVE, DRAIN RELIEF	1					
21	59015-00200		SPRING	1					A
22	60728-02800		SEAT	1					
23	60728-08800		GASKET, VALVE LOWER	1					
24	51727-06502		SLUG	2					
25	51727-06900		RETAINER	1					
26	51727-07000		RING	1					
27	58628-01702		PIN, STOPPER	1					A
28	58828-11001		VALVE	1					
29	58828-11100		SPRING	1					A
30	58828-13702		COVER	1					
31	58828-13801		COVER	2					
32	58828-14200		BOLT	5					A
33	62628-00030		DETENT ASSY	2					
34	62628-00800		PLUG	1					A
35	62628-03100		PLUG	2					A
36	62628-03601		SPOOL, CLUTCH VALVE	1					
37	62628-03700		PISTON	1					A
38	62628-03800		PLUNGER, CLUTCH VALVE	1					
39	62628-13900		SPRING	1					A
40	62628-04100		SPRING	1					A
41	62628-04200		SPRING	1					A
42	62628-04400		PLUNGER	1					
43	69365-51300		SPOOL	1					
44	69365-21800		PISTON	1					A
45	05530-20100		PLUG	1					
46	F3150-00800		O-RING	1					A
47	05615-10014		RING, RETAINING	3					
48	05616-10024		RING, RETAINING	3					
49	F1597-06010		SCREW, SET	1					
50	F2500-08000		WASHER, PLAIN	2					A

セレクト ハルブ  
SELECTOR VALVE

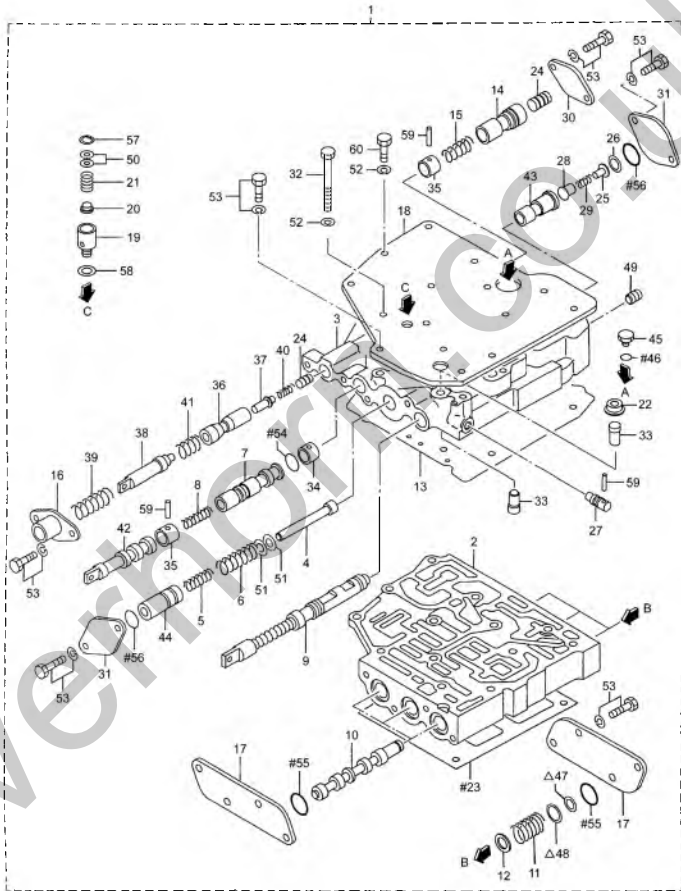

セクタバルブ  
SELECTOR VALVE

見出 番号 REF. -NO.	部品番号 PART NO.	代 替 R / P 記 録 S C E N E S P 記 号	部品名称 および 記事・仕様記号 PART NAME & DESCRIPTION		個 数 Q T Y	型式および適用号機 MODEL & APPLICABLE SERIAL NO.				新 規 M V R D
						MG500S				
						FROM#-	-@UPT0			
51	F2500-12000		WASHER. PLAIN		2					A
52	F2515-08000		WASHER. SPRING		13					A
53	F1805-08020		BOLT. W./WASHER	B/W	18					A
54	F3150-01500		O-RING		1					A
55	F3150-02500		O-RING		6					A
56	F3150-03000		O-RING		2					A
57	F3202-01800		RING. SNAP		1					A
58	F4202-18000		GASKET		1					A
59	F8001-40030		ROLLER. BEARING		3					A
60	F1035-08070		BOLT		8					A